

## From Nickel-Cadmium To Nickel-Hydrate Fast Battery Charger

---

J. NICOLAI, L. WUIDART

### INTRODUCTION

Today, many cordless and portable equipment are supplied by a rechargeable battery (Nickel-Cadmium, NiCd or Nickel-Hydrate, NiMH). Individual applications such as portable phones, camcorders, cordless power tools, portable appliances and audio equipment highlight the enormous contribution made by rechargeable batteries to our comfortable lifestyle.

NiCd battery chargers charging in one hour and even less are already widespread. Ultra fast charging of NiCd batteries in less than 15 minutes is a very attractive feature in applications where the battery is rapidly discharged, as in power tools such as cordless drills [1].

Nevertheless, when fast charging, the use of a non-adapted charge termination method may lead to a significant reduction of the battery service life. This could cause a prejudice against the appliance manufacturer's image, as when the battery service life is reduced, the user is practically led to a costly replacement of the complete battery pack.

The trend is now to replace NiCd batteries by the more environmentally friendly NiMH batteries. Several charger applications such as notebook computers and portable phones already require NiCd /NiMH compatible battery chargers. In this case, the most common charge monitoring method used for a NiCd battery (negative delta voltage  $:-\Delta V$ ) is no longer suited to the NiMH battery.

In this application, the charge termination method is based on the detection of the inflexion point in the battery voltage curve. This inflexion point detection method is not only "NiCd-NiMH compatible", it also significantly increases the NiCd battery life-time when fast charging.

Such a performant charger can be totally managed by a low cost 8-bit microcontroller (MCU), the SGS-THOMSON ST6210. Safe charging is achieved by the combination of three back-up charge termination methods  $:-\Delta V$  detection, temperature monitoring and timer cut-off. An additional benefit of using such a 20 pin standard microcontroller lies in its high adaptability of application features.

The proposed charging power converters use the Switched Mode Power Supply technology (SMPS), operating from AC mains or DC voltage sources. A 35W/100kHz offline and a 15W/100kHz DC/DC chargers are described in this note.

## 1 CHARGE TERMINATION METHODS

Basically, NiCd and NiMH batteries are charged by a constant current source (see Figure 1).

Figure 1. A battery charger is made of a constant current source controlled by a microcontroller which monitors the battery voltage variation with its internal analog-to-digital converter

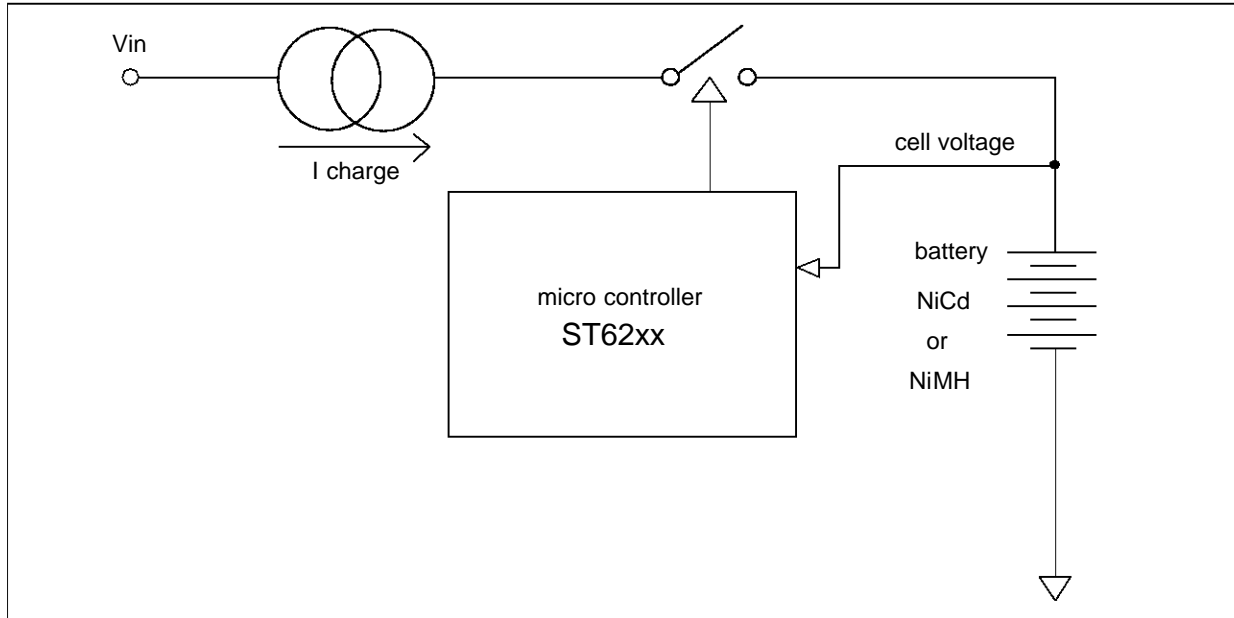

As soon as the full capacity of the battery has been detected by the microcontroller, the charging is stopped by turning the current off. Schematic examples of power converters operating as current sources are given later. The same converter hardware can be used in two different charging methods depending upon the appliance requirements.

### 1.1 The $[-\Delta V]$ method

When a NiCd battery reaches full charge, its voltage decreases slightly (see Figure 2). The negative delta voltage method  $[-\Delta V]$  consists of stopping the charge as soon as the voltage slope versus time becomes negative. This first charge termination technique is optimized to fast charge a NiCd battery to its full capacity.

Figure 2. The negative delta voltage method fast charge is terminated at point A.

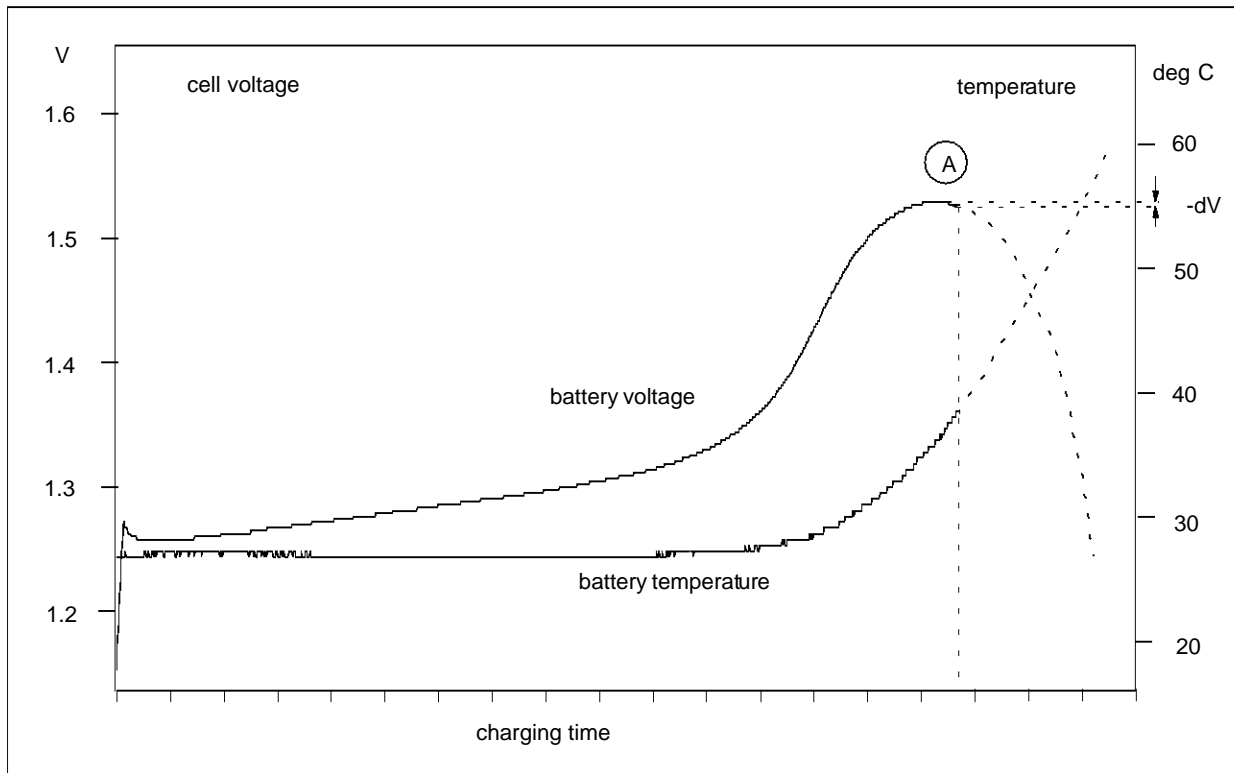

In fact, a NiCd battery charged with the  $[-\Delta V]$  method is slightly overcharged: Figure 2 shows that the battery temperature has substantially increased at point A when charge is terminated, which may decrease the life-time of the battery. More precisely in Figure 3, most of the current fed to the battery between point B and the negative voltage drop A is not directly converted into active battery charge, but into heat. This can be seen in the temperature curve shown in Figure 3. The point B corresponds to the inflexion point of the battery voltage curve versus time.

The  $[-\Delta V]$  method is definitely no longer suited when it comes to charging NiMH batteries: the NiMH charging reaction is permanently exothermic (releases heat), so the battery temperature would become excessive in its  $[-\Delta V]$  area of the voltage curve (see Figure 3).

Another characteristic of the NiMH batteries makes the  $[-\Delta V]$  method unsuitable: some types of NiMH batteries do not exhibit a significant voltage drop as NiCd batteries do when reaching their full capacity.

1.2 The inflexion point method

A second charge termination method much more adapted to NiMH batteries consists of detecting the inflexion point of the voltage curve, thus avoiding any excessive overheating of the battery. This method therefore significantly increases the battery life-time.

Figure 3. Fast charge terminates at point B in the inflexion point method.

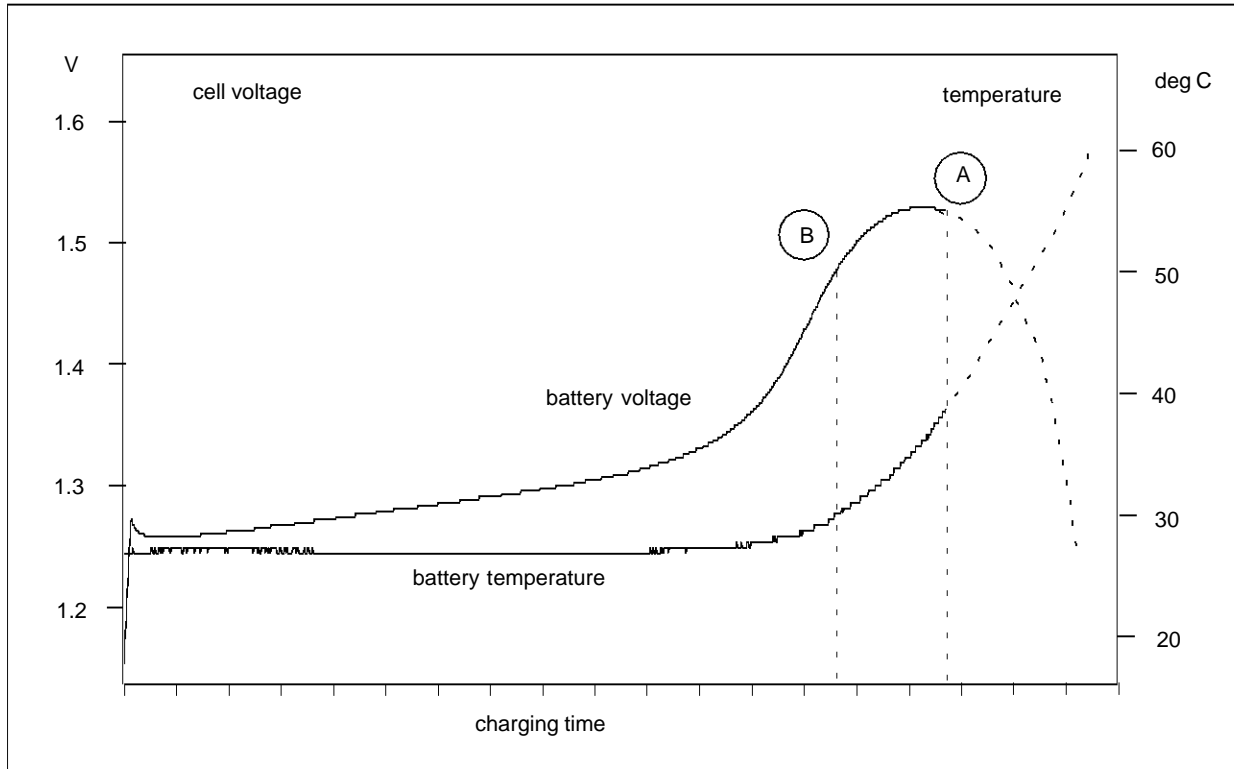
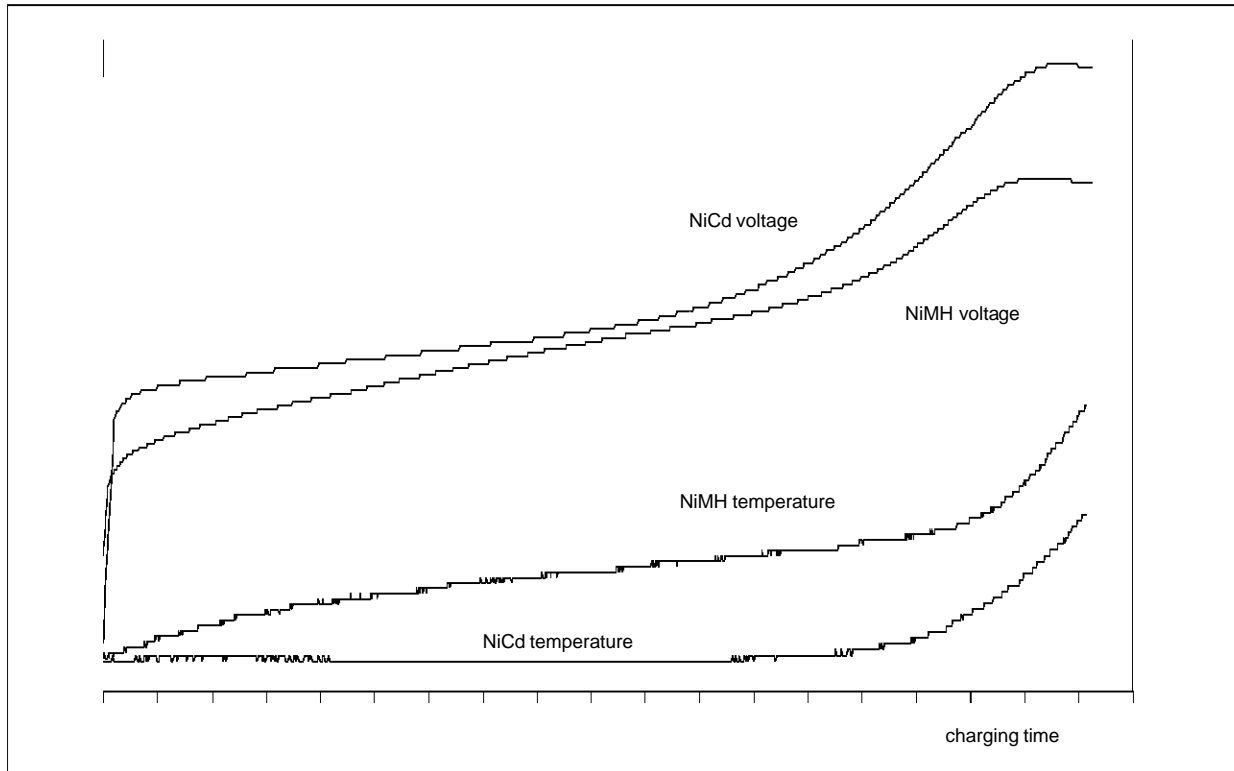

Figure 4. NiMH versus NiCd charging characteristics: the NiMH battery temperature rise is larger during fast charge, and its  $-\Delta V$  is less important, as its voltage slope variation.



Detecting the inflexion point of the voltage curve with the MCU requires the evaluation of the first derivative of the battery voltage curve versus time, and to detect its summit.

## 2 PRINCIPLE OF THE INFLEXION METHOD

Every 4 seconds, the analog to digital converter (ADC) of the ST6210 microcontroller measures the battery voltage and temperature. If the temperature is above a predetermined threshold (40 degrees Celsius for example), fast charge is terminated.

The battery voltage is actually measured several times in series, and an average of the measurements is made, to reduce measurement errors due to high frequency noise (for example generated by a switched mode charging current).

Further, a rolling average of the present and previous measurements is made, to remove low frequency noise due to electrochemical battery voltage variations (see previous description of this technique in bibliography reference [1]).

This averaged battery voltage data is used to extract a time derivative, by calculating the difference between present voltage and the voltage  $n$  samples earlier. Because of the voltage digitization, which is measured by the ADC of the MCU, the first derivative curve features a typical discontinuous aspect (see Figure 5).

For this reason, the MCU calculates a digital smoothing of this discontinuous derivative. The inflexion point is then identified by detecting the first highest summit encountered on the smoothed derivative curve (point B in Figure 5).

When this summit is detected, fast charge is terminated.

Figure 5. Inflexion point method.

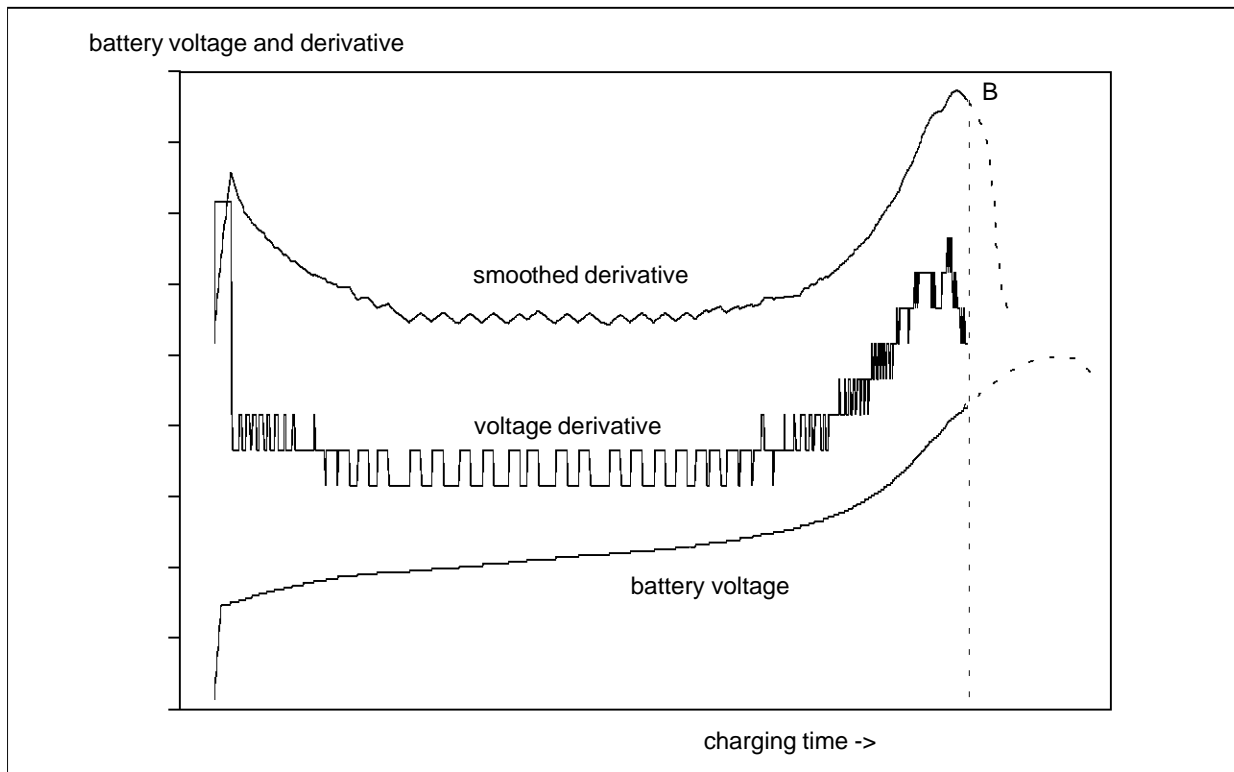

### 3 CHARGE CONTROL PROGRAM DESCRIPTION

The microcontroller detects the inflexion point in the battery voltage versus time curve while charging. When full charge is detected, the MCU puts the charger in trickle charge mode. As safety protection, the MCU also terminates fast charge if  $-\Delta V$  is detected, or the battery temperature exceeds a predetermined threshold, or a timer with programmable time duration expires.

Figure 6 shows the simplified flowchart of the program for the complete charge control. The overall system is reset after each new input source voltage connection. It is also reset when a charged battery is removed, and replaced by a discharged battery.

Figure 6. Simplified program flowchart.

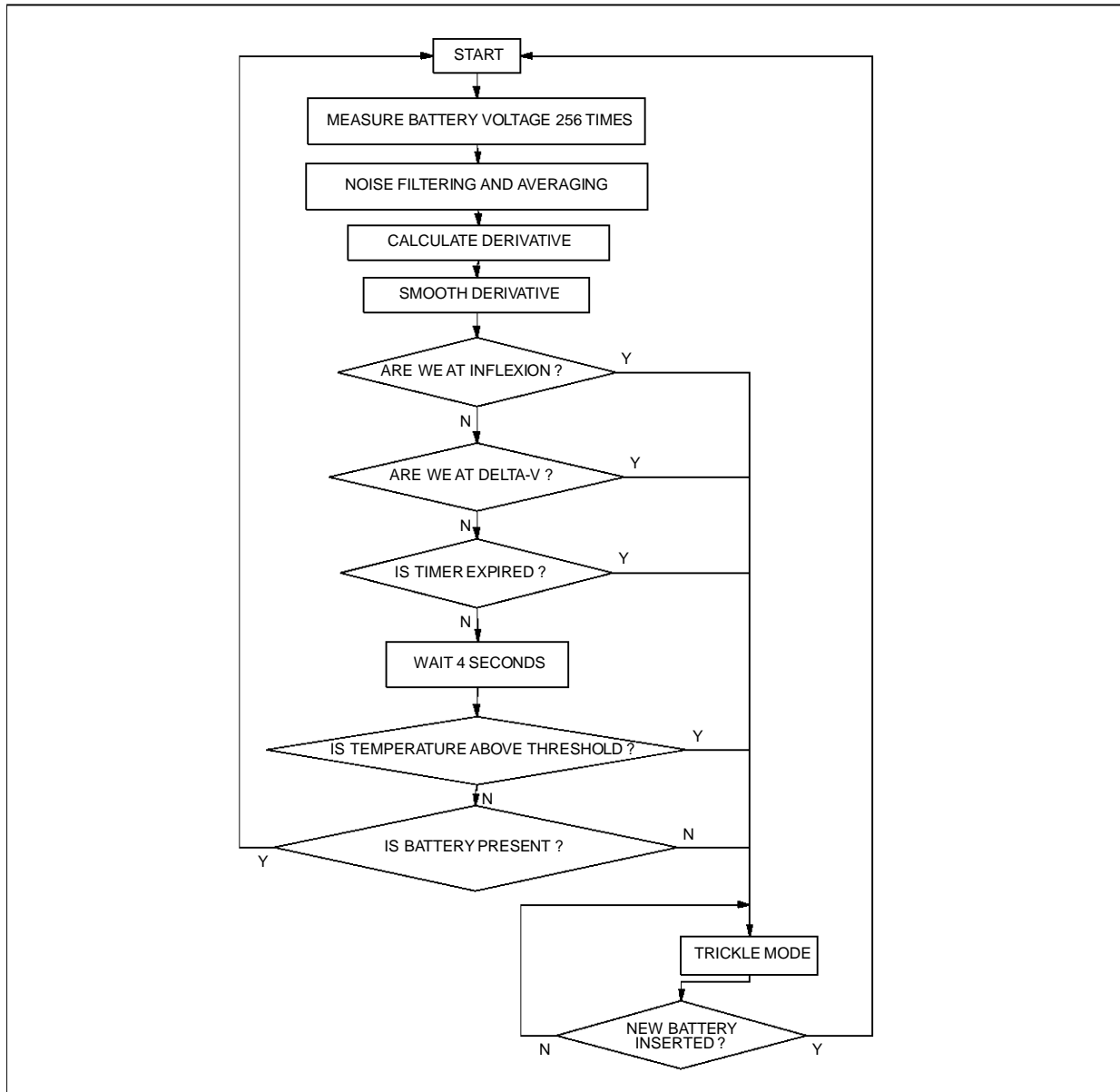

4 TEST RESULTS

Figures 7 and 8 show curves of a NiCd battery charge respectively terminated by  $-\Delta V$  and inflexion point methods. A similar comparison is made with a NiMH battery in Figures 9 and 10. The charging current is 2.2 A, the NiCd battery was a 1.4 Ah type and the NiMH battery a 2.2 Ah type. These measurement results clearly show that the battery temperature increase is much smaller with the inflexion method than with the conventional  $-\Delta V$  method. Moreover, these curves demonstrate that a one hour charge of NiMH batteries can be properly monitored by the ST6210 MCU.

Figure 7. Charge of a 1.4 Ah NiCd battery with the  $-\Delta V$  method: charging current 2.2 A, total time 48 mn, temperature increase 9.6°C.

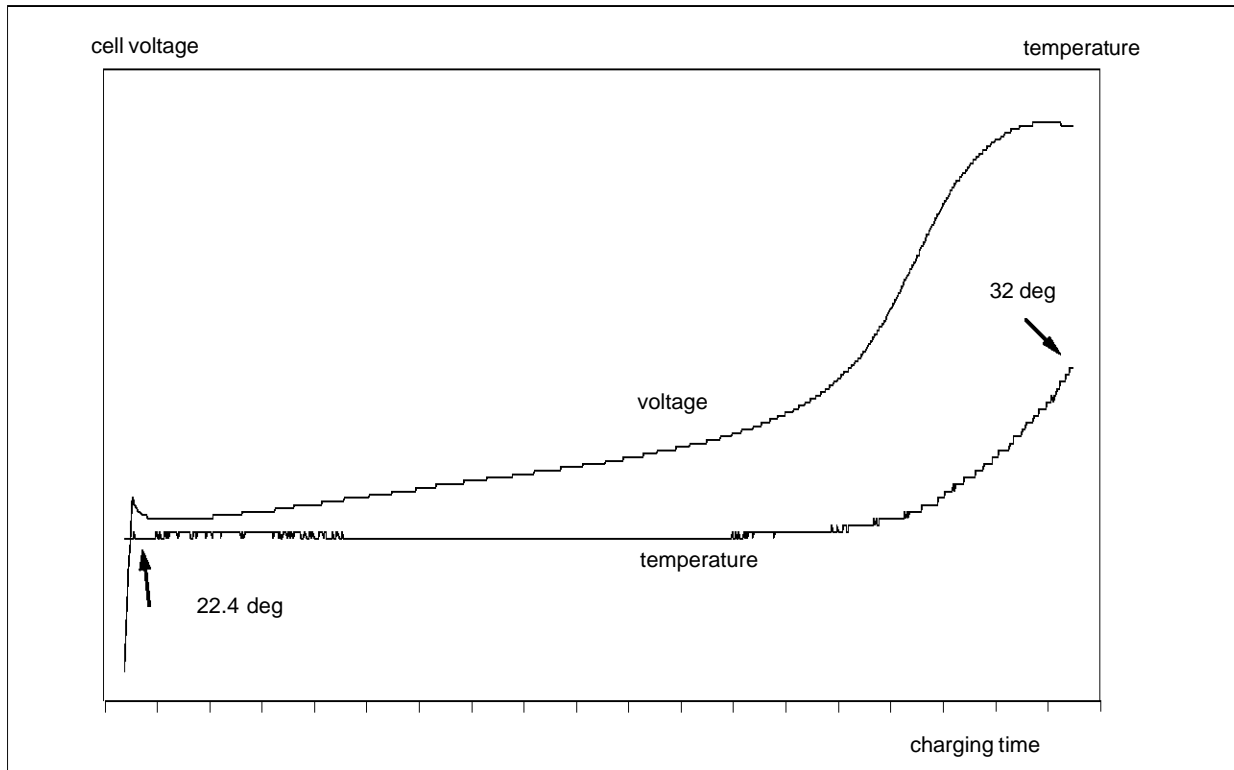



Figure 8. Charge of a 1.4 Ah NiCd battery with the inflexion method: charging current 2.2 A, total time 41 mn, temperature increase 5°C.

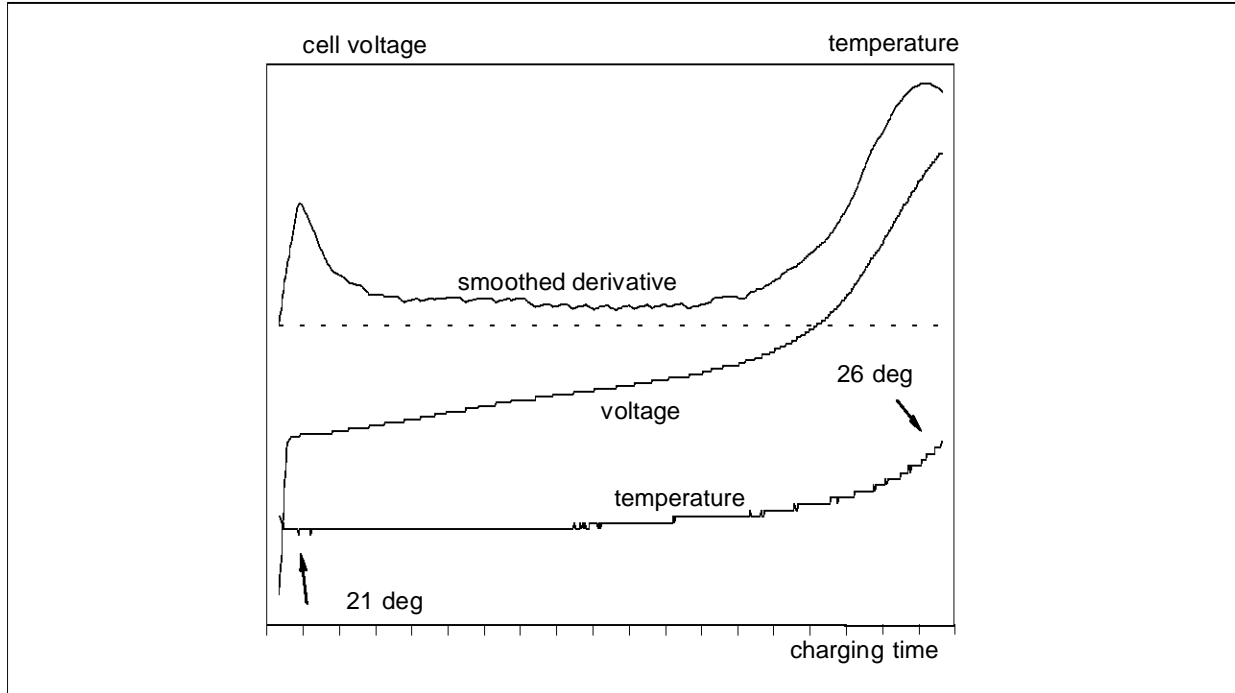
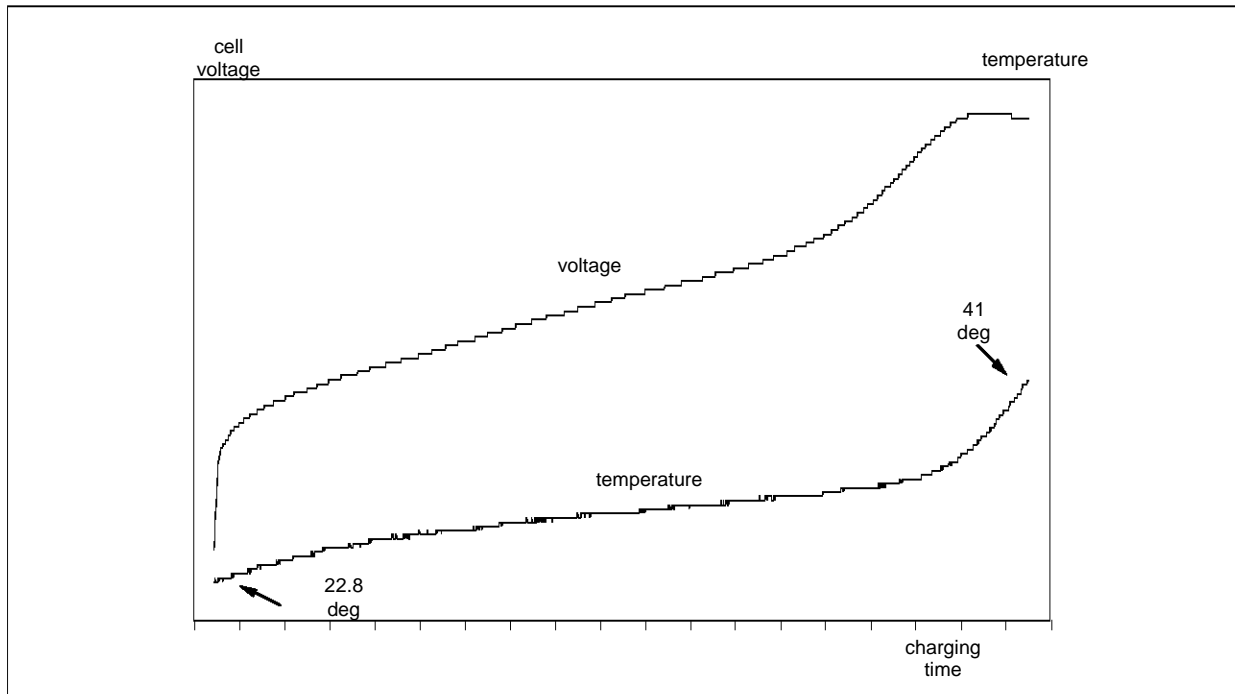
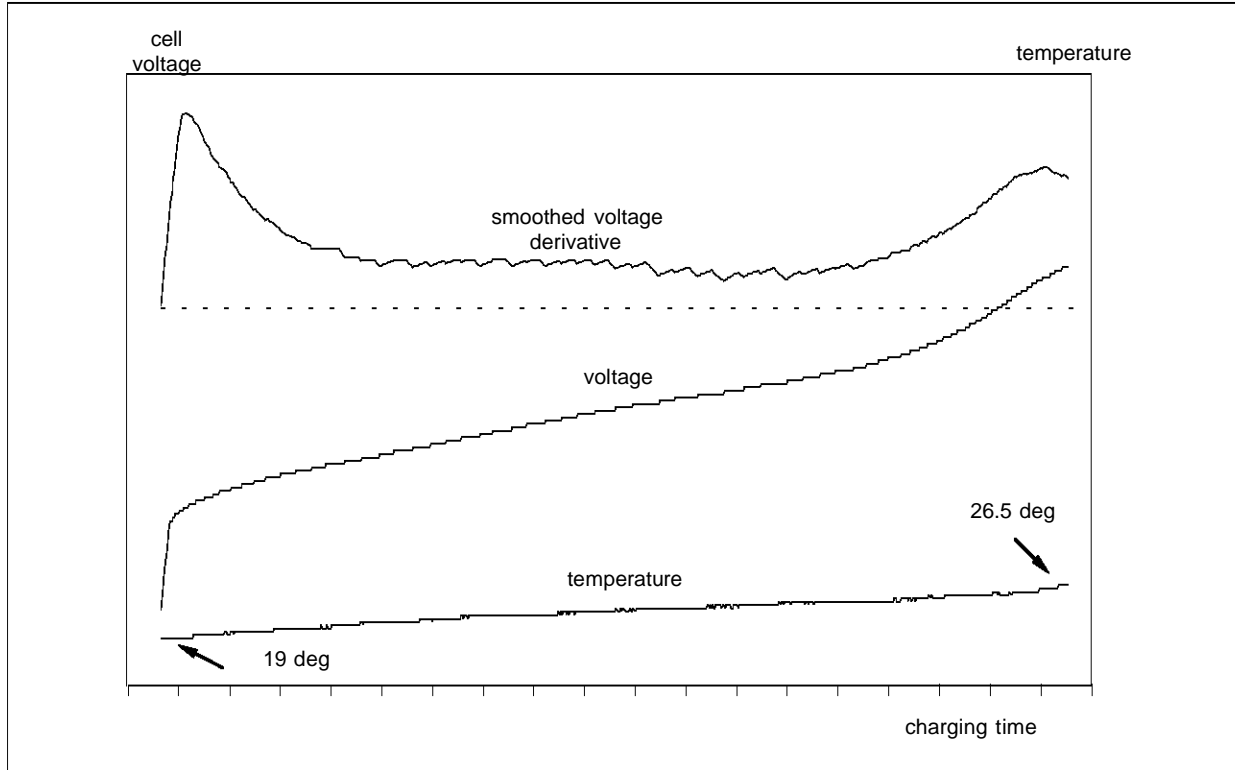

Figure 9. Charge of a 2.2 Ah NiMH battery with the  $-\Delta V$  method: charging current 2.2 A, total time 63 mn, temperature increase 18.2°C.



# FROM NICKEL-CADMIUM TO NICKEL-HYDRIDE FAST BATTERY CHARGER

Figure 10. Charge of a 2.2 Ah NiMH battery with the inflexion method: charging current 2.2 A, total time 57 mn, temperature increase 7.5°C.



Charge of different battery types with an 2.2 A current source.

Battery	Monitoring	Duration	Temperature increase
NiCd 1.4 Ah	-[ΔV]	48 mn	9.6°C
	inflexion point	41 mn	5°C
NiMH 2.2 Ah	-[ΔV]	63 mn	18.2°C
	inflexion point	57 mn	7.5°C

5 CHARGER SCHEMATIC EXAMPLES

5.1 Block diagram

The charger is a power supply operating as a constant current source. Such a current source can be made with a SMPS working from the AC mains or from a DC voltage source. Figures 11 and 12 give block diagrams of an offline SMPS charger and a DC to DC charger.

Figure 11. Block diagram of an off-line SMPS charger.

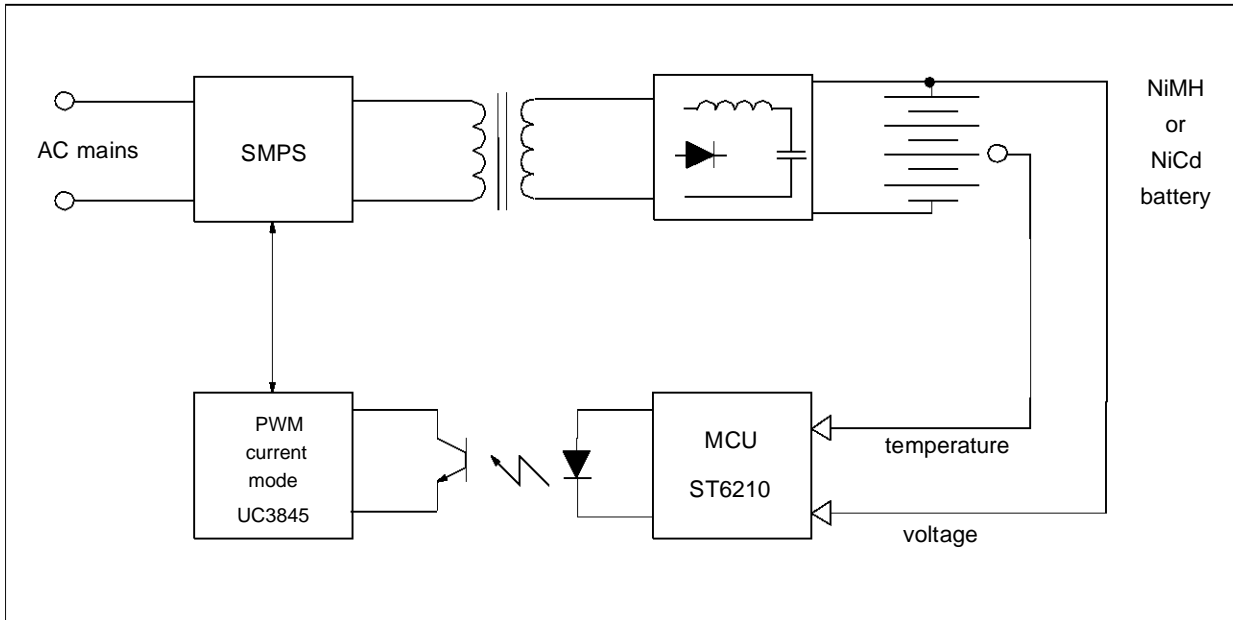
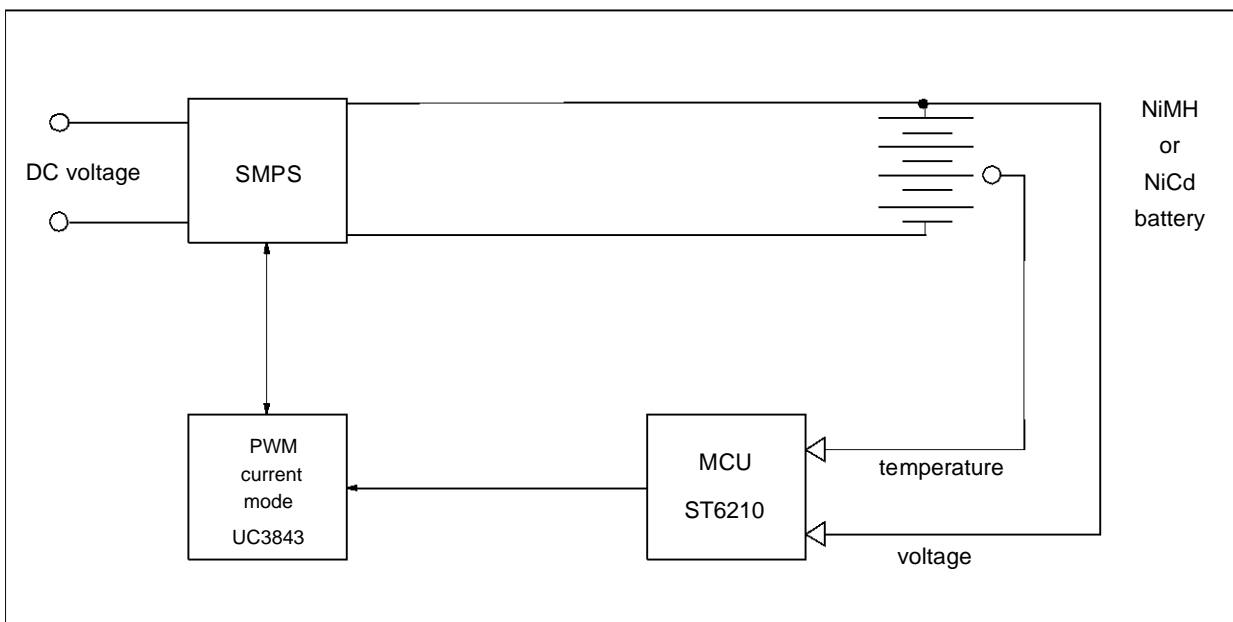

Figure 12. Block diagrams of aDC/DC charger.



### 5.2 Battery charger examples

#### Offline charger

Figure 13 gives an example of an offline 35 watt battery charger working at 100 kHz. This SMPS can deliver up to 3.5 amps DC to a 6 cell battery. Typical charging time of a 1.4 Ah 7.2v NiCd battery pack is around 30 minutes. This offline charger is an asymmetrical half bridge totally controlled from the primary side with a standard PWM control IC, the UC3845, regulating in current mode (see bibliography [3]).

The asymmetrical half bridge structure allows the use of two standard 500V power MOSFETS IRF820 without snubber network, as voltage across each power MOSFET is systematically clamped to the input DC voltage by two demagnetization diodes (BYT01/400). The MCU controls the SMPS section through a single optocoupler, either in battery charge mode or in trickle mode.

Note that the high side power MOSFET is simply driven by an auxiliary winding of the power transformer, avoiding the use of an additional pulse transformer.

The switching frequency is set at 100 kHz in order to keep the magnetic parts to a reasonable manufacturing cost level (see bibliography [2]). The power transformer and the output inductor can be integrated on a single ferrite core to allow a significant shrinking of the power converter size. This integrated magnetic technique has been used in a 80 watts / 15 minutes charger (see bibliography [2]).

By a simple resizing of the discrete power devices ratings, and by applying the  $[-\Delta V]$  termination method, the same off-line converter hardware has been used to charge a typical 7V2/1.2 Ah NiCd pack of cordless drill in less than 15 minutes (see bibliography [1] [2]).

#### DC/DC charger

Figure 14 shows a 15 watt 100 kHz battery charger supplied from a 12 Vdc input voltage. The DC input voltage can be supplied from a car battery, or from a 50/60 Hz transformer rectified voltage. This DC/DC charger is controlled by the PWM control circuit UC3843.

For example, such a 15 watt converter is able to deliver 1.5 amp DC, charging five 1500 mAh NiMH cells in approximately 1 hour.

Figure 13. This 35W/100kHz off-line charger is an asymmetrical half-bridge regulated in current mode from its primary side.

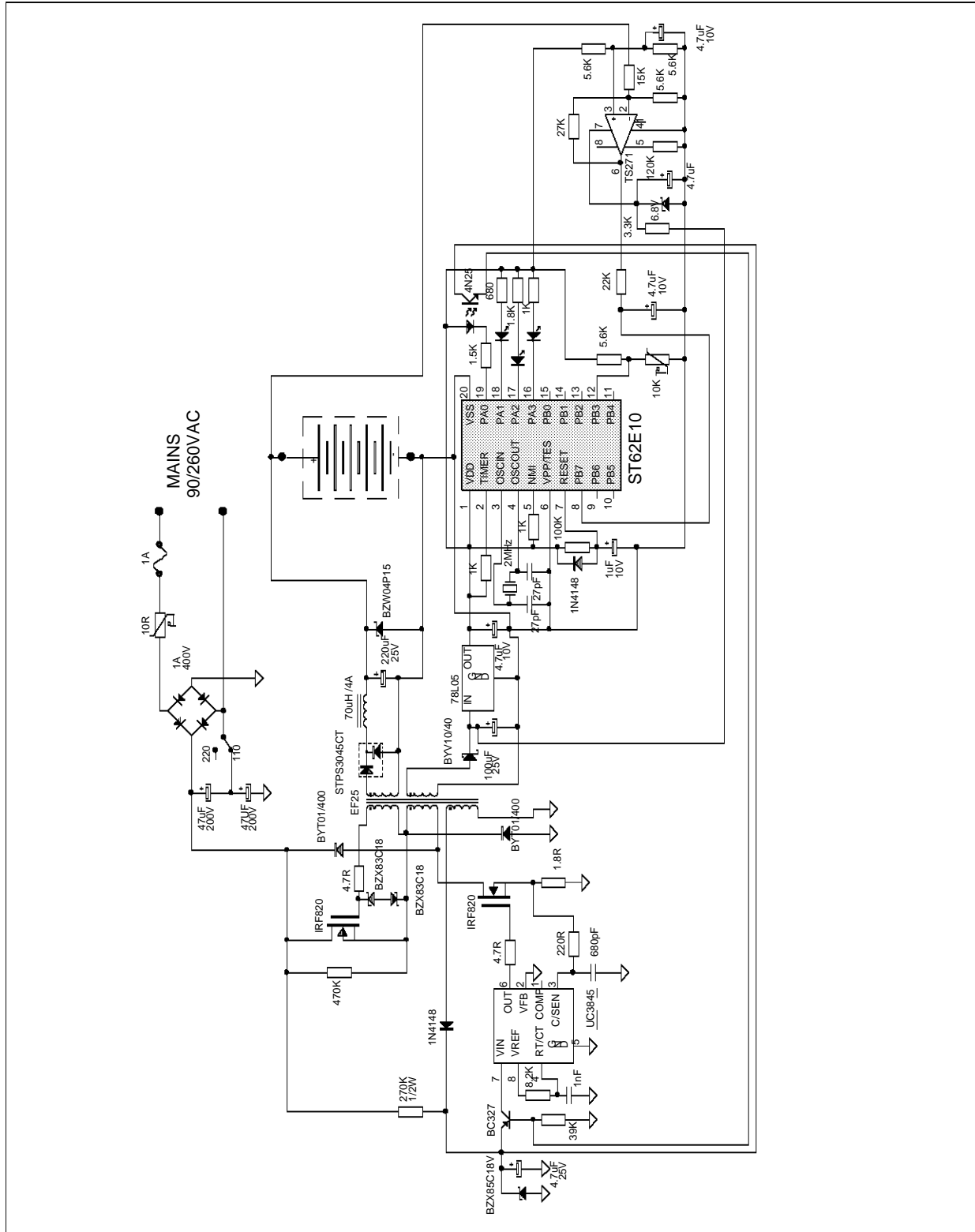

# FROM NICKEL-CADMIUM TO NICKEL-HYDRIDE FAST BATTERY CHARGER

Figure 14. This 15W/100kHz DC-to-DC charger is also driven by a low-cost PWM control integrated circuit, the UC3843.

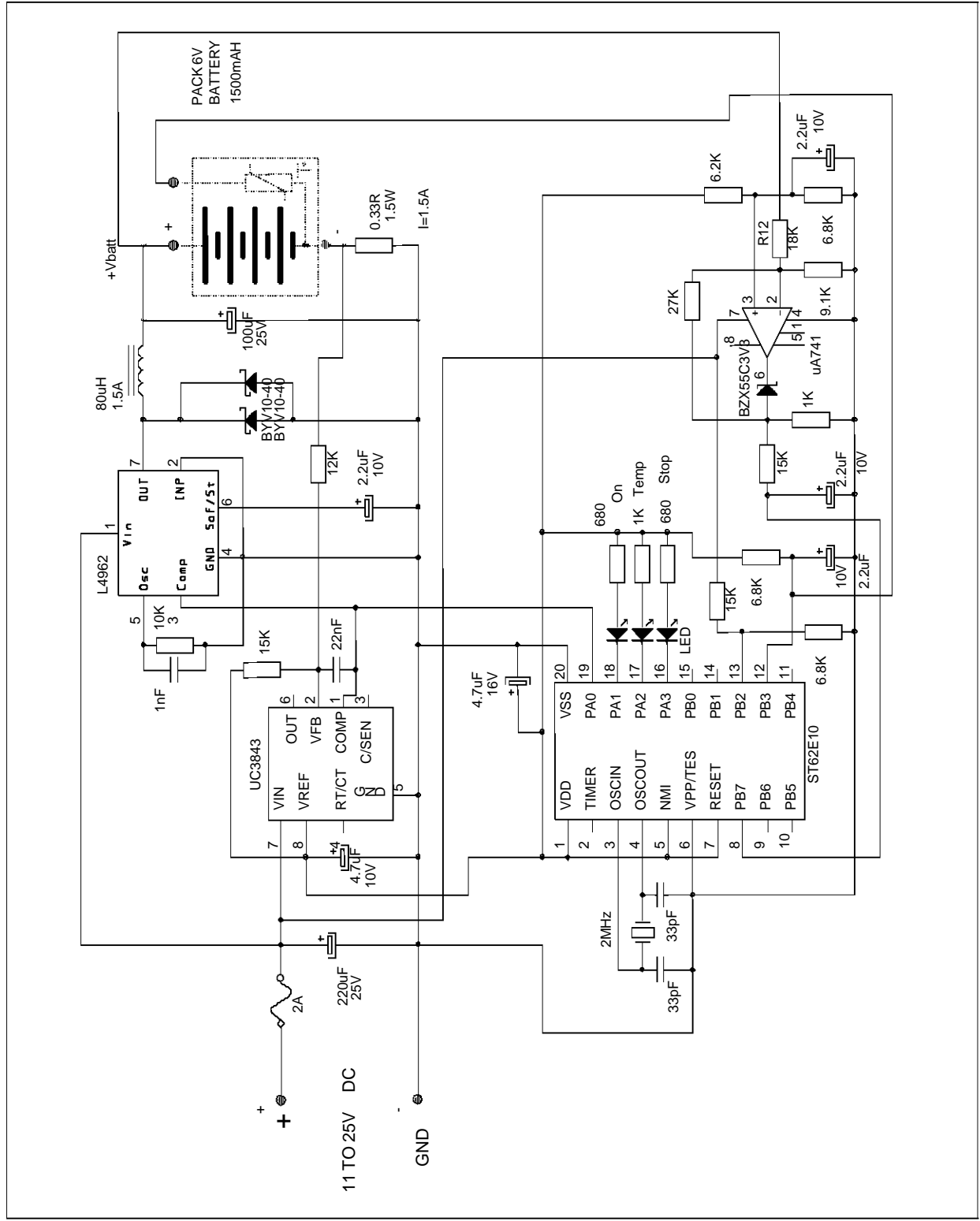

### 6 CONCLUSION

A relevant feature dominates today's electronic appliances - true portability. In these cordless appliances, fast charging of the battery packs is often considered by the user as a significant comfort improvement. Such an improvement can be achieved with a safe and cost-effective charger concept using an off-the-shelf microcontroller, the ST6210.

Moreover, the present battery charger concept is NiCd/NiMH compatible, meeting the current trend to progressively replace the NiCd battery by the more environmentally friendly NiMH battery.

The charge termination method is based on the detection of the battery voltage inflexion point in order to avoid any excessive overheating of the battery. Such a charge technique significantly improves the battery service life, preventing the user from untimely replacing his battery pack by a costly new pack. In addition, this low cost microcontroller provides a safe charge by combining three other back-up termination methods typical of high end dedicated control circuits :  $[-\Delta V]$  detection, battery temperature monitoring and timer cut-off.

The natural programmability benefit of such a microcontroller-based charger design allows the designer to easily implement additional user interface functions. For example, a "gas gauge" function indicating the remaining battery capacity to the user could be easily added to the present basic program, whilst retaining the same charger hardware structure. Finally, the major benefit of using this off-the-shelf ST6210 approach lies in the high adaptability of its application features.

### 7 REFERENCES

- [1] - Ultra-fast NiCd battery charger using ST6210 Microcontroller  
AN 433 / L. Wuidart, P. Richter (SGS-THOMSON Microelectronics)
- [2] - An ultra-fast NiCd battery charger concept  
43rd International Appliance Technical Conference, May 5-6, West Lafayette, Indiana  
U.S.A. / L. Wuidart
- [3] - A cost effective ultra-fast NiCd battery charger  
AN 486 / L. Wuidart, JM. Ravon (SGS-THOMSON Microelectronics)

)

Information furnished is believed to be accurate and reliable. However, SGS-THOMSON Microelectronics assumes no responsibility for the consequences of use of such information nor for any infringement of patents or other rights of third parties which may result from its use. No license is granted by implication or otherwise under any patent or patent rights of SGS-THOMSON Microelectronics. Specifications mentioned in this publication are subject to change without notice. This publication supersedes and replaces all information previously supplied. SGS-THOMSON Microelectronics products are not authorized for use as critical components in life support devices or systems without the express written approval of SGS-THOMSON Microelectronics.

© 1994 SGS-THOMSON Microelectronics - All Rights Reserved

Purchase of I<sup>2</sup>C Components by SGS-THOMSON Microelectronics, conveys a license under the Philips I<sup>2</sup>C Patent. Rights to use these components in an I<sup>2</sup>C system, is granted provided that the system conforms to the I<sup>2</sup>C Standard Specifications as defined by Philips.

SGS-THOMSON Microelectronics GROUP OF COMPANIES

Australia - Brazil - France - Germany - Hong Kong - Italy - Japan - Korea - Malaysia - Malta - Morocco  
The Netherlands - Singapore - Spain - Sweden - Switzerland - Taiwan - Thailand - United Kingdom -  
U.S.A.